



GULL WINGS NEWSLETTER - APRIL 2016

Torrey Pines Gulls Radio Control Soaring Society (TPG)

AMA Charter Club 129

Website: www.torreypinesgulls.org

Editor – Dale Gottdank

Inside This Issue

- 1 Message from the President
- 3 What do **YOU** think?
Yahoo Forum
- 4 TPG Facebook page
Newsletter Update
Club Meetings, Contests and Activities
- 5 News from the Slope
- 8 Club Competition Activity
- 9 Club Membership Update
- 10 LSF (League of Silent Flight) Report
- 11 Sagitta 600 Scratch Build – Part 3
- 16 1980's TWF Sagitta – Part 2
- 18 Club Sponsors – Thank You!
- 19 Photo of the Month Contest
- 25 2016 Club Officers & Contact Information
- 26 2016 Contest & Activity Calendar (subject to change)
- 27 Quote of the Month



Dan Cummins

Message from the President

Hello Gulls,

March is nearly in the rear view mirror as I introduce the April newsletter.

It has been a full month of flying for the club. I was great to meet some new members at the Fun Fly the first weekend of the month. We had a great turnout and many of us flew until sundown! The second

weekend of the month we hosted twenty pilots from all over SoCal for the first Torrey Classic F3F Race since 2013! Conditions were perfect, and we were able to get in six rounds. Our very own Tim Traver took first place in the adult class, and Ray Pili won the unofficial foam class!

The monthly contest has had good luck with the weather in March. We were able to give Poway field its first haircut of the year. It will likely need at least one more before the International in May. The field should be in good condition for the League of Silent Flight at Poway the second week of April.....many of us are chasing the much coveted 30 minute TD flight this month for LSF.....should be very exciting!

We've had decent wind at the bluff this month; consistently good conditions most afternoons, and a handful of excellent wind events chasing behind winter storms passing through. I personally was pleased to make it out to Mt. Laguna the last weekend of the month for some epic flying with the somewhat rare warm easterly winds. If you haven't flown Mt. Laguna, you need to add it to your bucket list!

(continued next page)

Message from the President (continued)

This month, there is stuff happening every weekend! TPG will host both TD and DLG monthly contests, the LSF attempt at Poway on the 9th, and a Fun Fly at the Torrey Pines bluff on the 23rd. Additionally, many TPG members will participate in the Dave Kellogg Memorial at Dave's beach on the 16th, and head up to Ellwood State Beach for the Weasel Fest in Goleta on the 30th.

So, it is shaping up to be a great month to be a glider pilot!

Check the TPG website calendar for upcoming events!

Till next month.

Fly more, and build something cool!

Cheers!

Dan Cummins
2016 TP Gulls President



Trimmin' the Poway Field...or... 🎵 Green Acres is the place to be; Farm livin' is the life for me! 🎵

What do **YOU** think?

You can express your opinion at: www.torreypinesgulls.org.

We have a **QUESTIONS AND SUGGESTIONS** link in the drop-down menu that appears when you scroll over **TORREY PINES GULLS** next to **LOCATIONS, CALENDAR, MEMBERSHIP...** If you have any questions, concerns, suggestions, etc. for the board, here's your chance.



Join the Yahoo Forum!

From Lenny Brzezinski:

The Yahoo forum was formed Oct. 18th, 1999. There are over 200 members in the Yahoo Group. This group has many things to offer for the club. It is a way of communicating with each other. If you have any concerns you can post them here including other questions about almost anything having to do with flying, building, finding another person, and so on.

If you are new to the club, the website will give you a lot of information about the club. On the website there is a link that you can use to join the group. This group is moderated. Please use this group for flying related items. You can post on the Yahoo group files, photos, polls, members, and calendar. All of these sections are available to any member. I hope that your experience with this group will be great. On the TPG website, www.torreypinesgulls.org, you can follow the **YAHOO FORUM** link in the drop-down menu that appears when you scroll over **TORREY PINES GULLS** next to **LOCATIONS, CALENDAR, MEMBERSHIP.**

Check out the TPG Facebook Page

From John Blasko:

If you haven't had a chance yet, check out our TPG Facebook page:

<http://www.facebook.com/TorreyPinesGulls>



Dale Gottdank

Newsletter Update - Dale Gottdank

Spring Has Sprung!



Celebrate by contributing to our [GULL WINGS NEWSLETTER](#)

Please Send Pictures! Send an article, perhaps. It doesn't have to be a "novel," just a paragraph or two about something that interests you related in some way to RC soaring...even something interesting you happened upon on the internet. I'd like to have the newsletter published by the first week of every month. If there's a project you're working on, don't just post it on RCGroups...share it with your club! **This month, we have the last of Eric Metzdorff's 3 part Sagitta 600 scratch build.**

To make the timely issue possible, I need the club members' support and help in providing me with recent pictures, articles and any upcoming events. If there are too many, we'll save some for the next issue.

Please send in your articles or photos (dgottdank@gmail.com) by the **25th** of each month so they can be included in the monthly newsletter. The newsletter can be found on the Torrey Pines Gulls website at <http://www.torreypinesgulls.org>

Club Meetings, Contests and Activities

As we did last year, TPG will continue to host monthly contests, fun-fly events, and onsite clinics. General meetings will coincide with non-competitive events throughout the year. Be on the lookout for upcoming details and scheduling for all TPG and related events in the Newsletter, Newsletter Calendar in this issue and on the Torrey Pines Gulls website at:

<http://www.torreypinesgulls.org> and
<http://www.torreypinesgulls.org/calendar/>

News from the Slope – Ray Pili, Slope Coordinator



Ray Pili

Welcome Back El Nino Storms!!!!

Saturday March 5th was a no-name Fun Fly at Torrey with fantastic spring conditions.



The morning was sunny with light winds that built to a nice breeze by noon. My buddy Albert was flying by 10:30 along with a couple PGs. Within an hour the skies were getting busy with tandem rides and Slopers.

Jason Lilly (the younger one), Tom (Coachella) and Albert all were checked out to fly Torrey.

I missed ex-president Marty, and George. Good to see them out on the slope.

Many thanks to Matin for giving away his Factory Second NCFM Cores.

Saturday April 23th will be the Foamy Fun Fly. Bring your EPP and let's fly.

Here are some photos from the March event:



Eric, Bailv, President Dan and "HowstheWind" Grea. Their aood side.

(continued next page)

News from the Slope (continued)



Tom's PSS Vampire.



Scott's Slopers



Craig's Slopers



Eric's Slopers

(continued next page)

News from the Slope (continued)



The younger Jason Lilly on the right.



New slope pilot Albert



Ex-president Marty and Matin. Photo by Greg H.

Safety tip:

Epoxy is a common adhesive for RC Modelers. But some people develop a reaction to repeated exposure to epoxy. This site describes how to properly use and dispose of Epoxy.

<http://www.prosetepoxy.com/safety.html>

**Blue Skies,
Ray Pili**

Club Competition Activity

Thermal Duration



Mark Canfield

Thermal Coordinator/Winchmaster – Mark Canfield

For information, contacts, rules, etc. for past and upcoming Thermal Duration contests, check the following link on the Torrey Pines Gulls website: <http://www.torreypinesgulls.org/event/thermal-duration-contest-march/>

or contact Mark Canfield at mcanfield5@roadrunner.com

More information may be shown in the F3X Vault site (<http://www.f3xvault.com>) as TPG coordinates with the Vault for contest sign-ups, tasks, results, etc.

Hand Launch



Tim Traver

F3K Coordinator – Tim Traver

For information, contacts, rules, etc. for past and upcoming Hand Launch/DLG contests, check the following link on the Torrey Pines Gulls website: <http://www.torreypinesgulls.org/discus-launch-glider-series/> or contact Tim Traver at TimTraver@gmail.com

More information may be shown in the F3X Vault site (<http://www.f3xvault.com>) as TPG coordinates with the Vault for contest sign-ups, tasks, results, etc. and in this RCGroups thread: <http://www.rcgroups.com/forums/showthread.php?t=2318718>

Club Membership Update – Bill Eckles

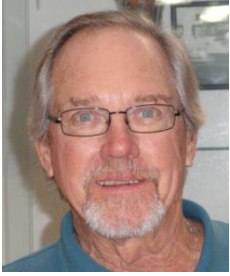

Bill Eckles

Spring's apparently here and we're getting occasional days of good wind. Even some great ones. So, please assure your legitimacy with a membership renewal for 2016. We're creeping up in our membership roster and have even added some new guys...still no females, but we'll worry about changing gender biases later.

We're now at 86 current memberships, all of them super guys making up a super club. The board of directors is busy planning events and celebrations as well as grooming our three sites. We're active in three prime areas; thermal, slope and hand launch with good management of the contests in all areas. So, come out and get busy getting to know each other.

Thanks for all the support and keep it coming!

Bill Eckles, Membership Chairman

Every year we need a good strong membership to continue to provide the services we offer:

- ✓ Access to three Flying Fields in La Jolla, Encinitas and Poway.
- ✓ Quarterly (or thereabouts) fun-fly clinic events to be held at our thermal soaring fields and at Torrey Pines Gliderport, where members will have ample opportunities to take advantage of our trio of excellent flying sites. Be on the lookout for upcoming details and scheduling.
- ✓ A group of guys who can answer just about any question you might ask, and do it with a smile.
- ✓ Contests that bring out world class competitors from around the globe.
- ✓ Competition and help for *you*, regardless of your skill level.
- ✓ A holiday party that's the envy of most gourmands in Southern California.
- ✓ A website for current and past information www.torreypinesgulls.org
- ✓ An interesting monthly newsletter with current information to help keep members informed
- ✓ We are an AMA Chartered Club #129, with benefits - field Insurance etc.

Dues are as follows:

- ✓ Dues for the membership (calendar) year are as follows for submissions during.
- ✓ January through June \$60
- ✓ July through September \$30
- ✓ October through December \$60 (gives you a jump on next year)
- ✓ Full-time college students \$30 per year
- ✓ Juniors under 18 years \$15 per year
- ✓ Receive a *credit* of up to \$20, ten for each of up to two half-day work sessions helping the club.

If you haven't re-upped yet, or would like to join the club for the first time, go to www.torreypinesgulls.org and click on the tab "Membership". We'll make it as simple as possible to continue your membership.

Note: TPG membership information will not be shared or sold and will only be used to contact members for purposes of TPG business

LSF Report – Ray Pili

TPG League of Silent Flight Attempt Days



There were no scheduled LSF Attempt days in March but a few tasks were completed the first week of March.

My 60 min Slope task was completed with my replacement Ka-8 at Torrey with no radio issues. Dale Osborn completed his 5 min Thermal LSF1 task with his Blaster at Poway. On the same day, Don Lockhead completed his second 5 min thermal task as a replacement for his 15 min slope task for LSF 1, and I completed my 15 min thermal task with my Aerial Light.

**The next LSF Attempt day is Saturday April 9th, Pilots Meeting at 8:30 am.
I have LSF 1 Vouchers so just show up.**

Here's a table delineating the various tasks at each LSF level:

Requirements	Primary	Intermediate			Advanced
Level	I	II	III	IV	V
Thermal Duration	5 min.	15 min.	30 min	1 hr	2 hrs.
Slope Duration	15 min.*	1 Hr.*	2 hrs.*	4 hrs.*	8 hrs.
Precision Spot Landing	5 landings 3m (9.84 ft) or less	10 landings 1.5m (4.92 ft. or less)	None	None	None
Goal and Return	None	None	1km (0.62 mi.)	2km (1.24 mi.)	10km(6.2 mi)
Competition	None	6 contests** w/ 1 place or 3,000 pts	6 contests** w/ 2 place or 4,500 pts	6 contests** w/ 2 places and 1 win or 6,000 pts	6 contests** with 12,000 points including 3 wins

Blue Skies
Ray

Sagitta 600 Scratch Build – Eric Metzdorff

Finally, here's part 3 of Gulls member Eric Metzdorff's scratch build of a Sagitta 600 for slope soaring at Torrey. We'd like to thank Eric for taking the time to provide this informative presentation of a great project. Hopefully, it's inspired some of us to get one of those old kits out of the rafters, or even scratch build another classic.



Canopy blocks and center wing access panel ready for shaping.

Hold down screw must have a large flange surface. Luckily I had this one laying around. Nice thing about kits, is that all the hardware is included and does not need to be tracked down.

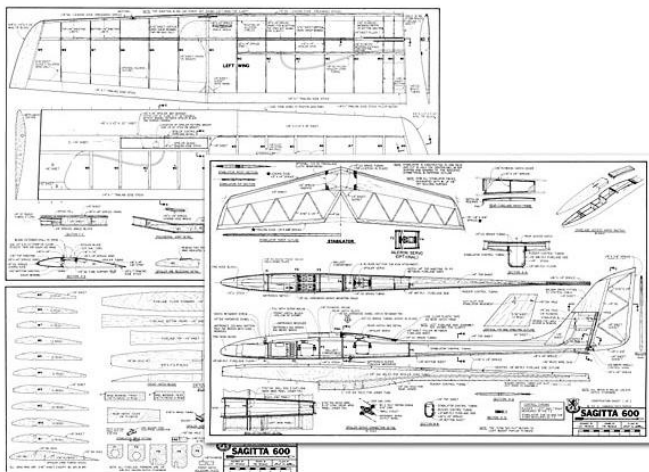
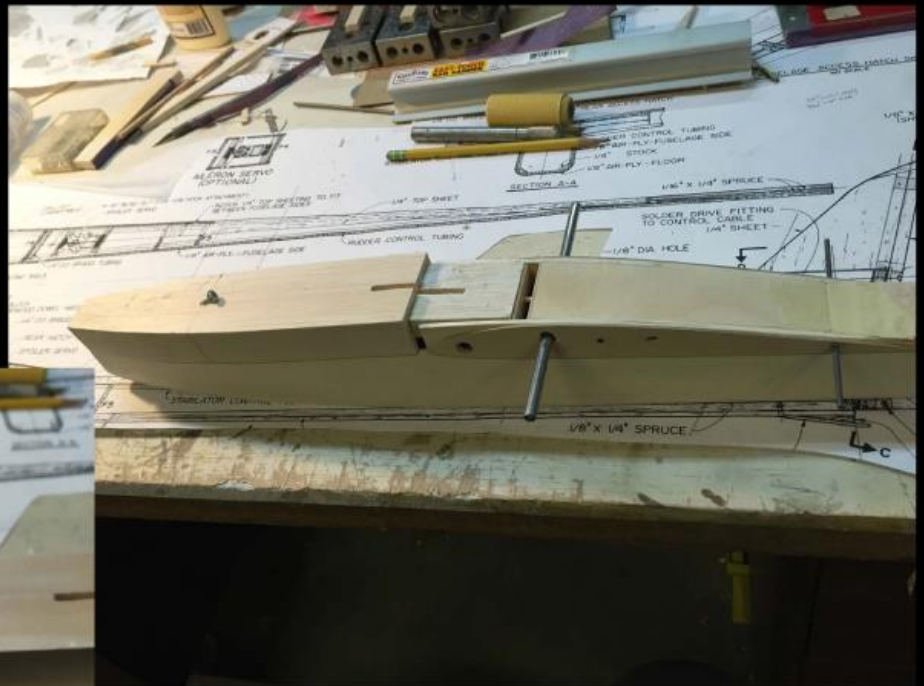

[more pics \(1\)](#)

Sagitta 600
 by Lee Renaud
 from RCMplans (ref:865)
 May 1982
 79in span
 Tags: Glider R/C
 all formers complete :)

(continued next page)

Sagitta 600 Scratch Build (continued)

Glued up and installed, ready for final sanding and fiberglassing. At this point all major assemblies are complete and ready for finishing and final assembly.



Fuselage has 2 cotes of 3/4oz cloth and is finished in Z-poxy as this sands nicely. Next few slides show bones view and covered view. Painting was somewhat time consuming in winter as you have to wait for the temperature to get above 70° for the gloss paint to work correctly. I will try to avoid painting in the dead of winter from now on. Enjoy the last few slides. Maiden flight at Torrey this Friday if weather cooperates.



Sagitta 600 Scratch Build (continued)



(continued next page)

Sagitta 600 Scratch Build (continued)



(continued next page)

Sagitta 600 Scratch Build (continued)



(the end...till the next build)

1980's TWF Sagitta! – Al Schmadtke

And here's some more from our friend Al in New York about his twisty-wing Sagitta!

Hello Gentlemen,

Attached, please see my chicken scratch drawings!

Lenny Hauf came up with the "twist wing" mod for the Sagittas that we flew back in the day. Lenny is the guy standing on the right with his modified Sagitta 900. In addition to the twist wing, he also added length to the straight sections of the wings in order to get to 112" wingspan. He either thickened or increased the size of the stab, I can't remember. We were all impressed with the way it flew (and the way he did so well our local contests) that it started to become a club mod. He shared his ideas freely and would even let you fly his planes! The complete package had a Rocket City captured tow hook!

So, with some re-engineering, a servo was jam mounted (top screwed) into a vertical position near the rear wing pin. A new pin was bent to a Z shape and epoxied into the tube on the wing. Du-Bro ball links were used to drive the twist wing. We picked a spot on the servo to anchor the metal ball part so we could get the effect of aileron differential. For the 600, the rear of the wing lifted about 3/8" while it only dropped about half of that. The concept behind not cutting ailerons into the wing was to save weight and drag. These were sweet planes to fly with this mod, even better than the poly version. Some guys left a small amount of poly, they felt it was an even better mod.

Our spoiler mod was to add two pieces of 1/16" ID brass tube. One tube was mounted to the shear webbing on the inboard side of the spoiler opening and the other to the outboard side of the spoiler. A 1/64" wire was bent in a U shape, with one leg at 1/2" long and the other leg about 1". The bends were made the same distance apart as the tubes were glued in. This became a torsion spring that held the spoiler closed during launch and high speed flight. Throw away the stick on weights that came in the kit!

I stumbled upon the article that Eric was writing and was very happy to see someone actually building a Sagitta. This was an extremely well designed, easy to build airplane and a very durable one too. I don't ever recall seeing a 600 blow up on the winch. We did bend the wing rods in the 900's! Carry on Eric!

Respectfully submitted,

Al Schmadtke
Former member Long Island Silent Flyers

(continued next page)

1980's TWF Sagitta! – Al Schmadtke

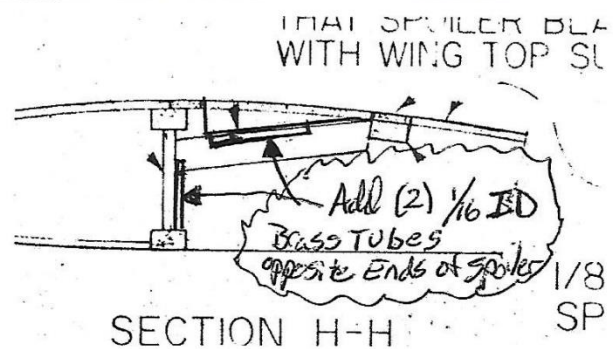
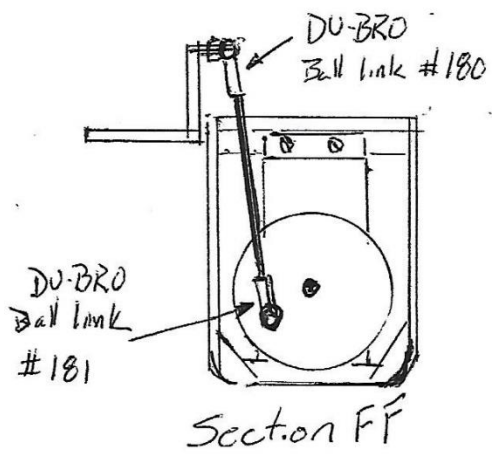
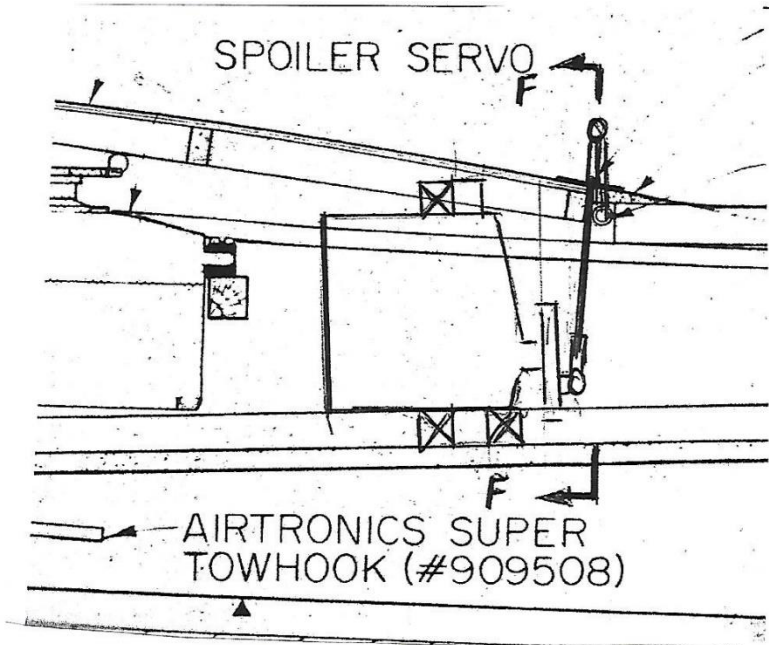

Club Sponsors

The Torrey Pines Gulls members would like to thank all the sponsors for their donations and supporting Torrey Pines Gulls Radio Control Soaring Society. Without the support of these fine companies, the success of many of the Club events would not have been possible.

To our members, when you are thinking of buying a hobby-related item, please consider these outstanding companies first. Please click on vendor's logo to go to their website for more information.

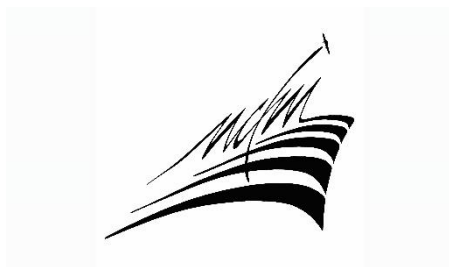

Photo of the Month Contest

Each month club members may submit photos of an activity related to soaring and the newsletter editor will post a **winner** to be chosen by the Board of Directors.

A yearly winner will be selected from among the monthly winners and will receive a prize (their photo will be used as the website and newsletter masthead AND will appear on the following year's club membership card). Needless to say, **horizontal format photos are preferred**. Email your photos (.JPG format preferred) to Dale Gottdank at dgottdank@gmail.com. Please provide your name, location of photo and photo description.



New artificial turf installed at the Torrey Pines Gliderport picnic table/pit area by L-R: Ray, Kevin, Mike, Sean, Robert (Ray P. & Kevin B.)



January Winner - Mr. Robert (Peterson) & son Cam flying their Skua at Torrey (Greg Houck)
(continued next page)

Photo of the Month Contest (continued)



Plane mounted camera view from Phil Davy's Xperience Pro Carbon 3.3 at Torrey



Camera catches Phil flying the Xperience



Come to papa!



February Winner – Phil Davy's Xperience Pro Carbon 3.3 camera view flying inverted over Torrey

(continued next page)

Photo of the Month Contest (continued)



Screenshot – Ka-8 DS'ing at Bill's Hill (Phil Davy)



Screenshot – Ka-8 DS'ing at Bill's Hill (Phil Davy)



February 6, 2016 Torrey Fun Fly (Ian Cummings)

(continued next page)

Photo of the Month Contest (continued)



Kat's Spirit Elite with seagull in pursuit at Torrey (Ian Cummings)



Kat's Spirit Elite with seagull at Torrey (Ian Cummings)



Kat flying his Spirit



March Winner – Sunlight under a Spirit Elite and a Torrey Pines Gull (Ian Cummings)

(continued next page)

Photo of the Month Contest (continued)



Launching foamies at the Torrey Classic Slope Race (Ian Cummings)



Launching moldies at the Torrey Classic Slope Race (Ian Cummings)



Tight turn at the Torrey Classic Slope Race (Ian Cummings)

(continued next page)



Torrey Sunset (Ray Pili)



April Winner – Torrev before El Niño Sauall (Ray Pili)

Club Officers and Contact Information

President	Dan Cummins	TPGulls@gmail.com
Vice-President	Ian Cummings	icummings@earthlink.net
Past President	Dan Cummins	TPGulls@gmail.com
Secretary	To be filled	
Treasurer	Don Lockhead	donloch@sbcglobal.net
Membership	Bill Eckles	tunabiker1@hotmail.com
Communications	Dale Gottdank	dgottdank@gmail.com
Winch Master	Mark Canfield	mcanfield5@roadrunner.com
F3K Coordinator	Tim Traver	timtraver@gmail.com
IHLGF Coordinator	Mike Smith	mike@themapsmith.com
Thermal Coordinator	Mark Canfield	mcanfield5@roadrunner.com
Slope Coordinator	Ray Pili	rpili2001@gmail.com
Safety Officer	Ray Pili	rpili2001@gmail.com
SC2 Representative	To be filled	
Webmaster	Steve Hurd	steve@torreypinesgulls.org
Historian	Gary Fogel	garyfogel@gmail.com
TP Soaring Council (TPG)	Ray Pili	rpili2001@gmail.com
TP Soaring Council (AMA)	To be filled	

Dan Cummins
President



Ian Cummings
Vice- President



Secretary

Don Lockhead
Treasurer



2016 Contest & Activity Calendar (subject to change)

Month	RES/ TD	CD	HLG	CD	Slope Race	SC ²	Club Activity
January	10	Mark Canfield			socalsloperacing.com (inactive site)		
February	14		27	Tim Traver		28 @ SWSA	6 Pilot Rating/Fun Fly @ Torrey 13 LSF Attempt Day
March	13	Cliff Hunter	26	Tim Traver	13 F3F Race 13-14 Torrey Classic	20 @ DSH	5 Fun Fly @ Torrey
April	10		30			17 @ SWSA	9 LSF Attempt Day 23 Foamy Fun Fly @ Torrey
May	15	Tom Watson	14-15 IHLGF			15 @ VVRC	14-15 IHLGF
June	12		18	Tim Traver		19 @ HSS	4 Katie Martin Tribute @ Torrey 11 LSF Attempt Day
July	10	Steve Condon	16	Tim Traver		17 @ ISS	23 TWP/PNF Fun Fly @ Torrey
August	14	Tom Watson	20			21 @ TOSS	13 LSF Attempt Day 23 August Scale Fun Fly @ Torrey
September	11		24			18 @ SULA	
October	09		22	Tim Traver		23 @ TPG	8 LSF Attempt Day
November	20		12	Tim Traver		20 RAIN DATE	
December	11						10 LSF Attempt Day

Note: Calendar subject to change at any moment without warning or notice. **Check the TPG Website for updates / more info.**
The SC2 schedule could change on availability of club field's check website: sc2soaring.com



Quote of the Month:

“The April winds are magical, and thrill our tuneful frames...”

~Ralph Waldo Emerson

